



ASCO Power Technologies™

ASCO Transfer Switch Overview

ascopower.com

Life Is On



Challenges



Reliably transfer loads between two or more power sources.



Service and maintain equipment without disrupting power to loads.



Reduce equipment space requirements.



Transfer loads without impacting downstream equipment.



Add capability for a "backup-to-the-backup".

What do these challenges have in common?

All of them can be solved by using transfer switches.

ASCO Solutions

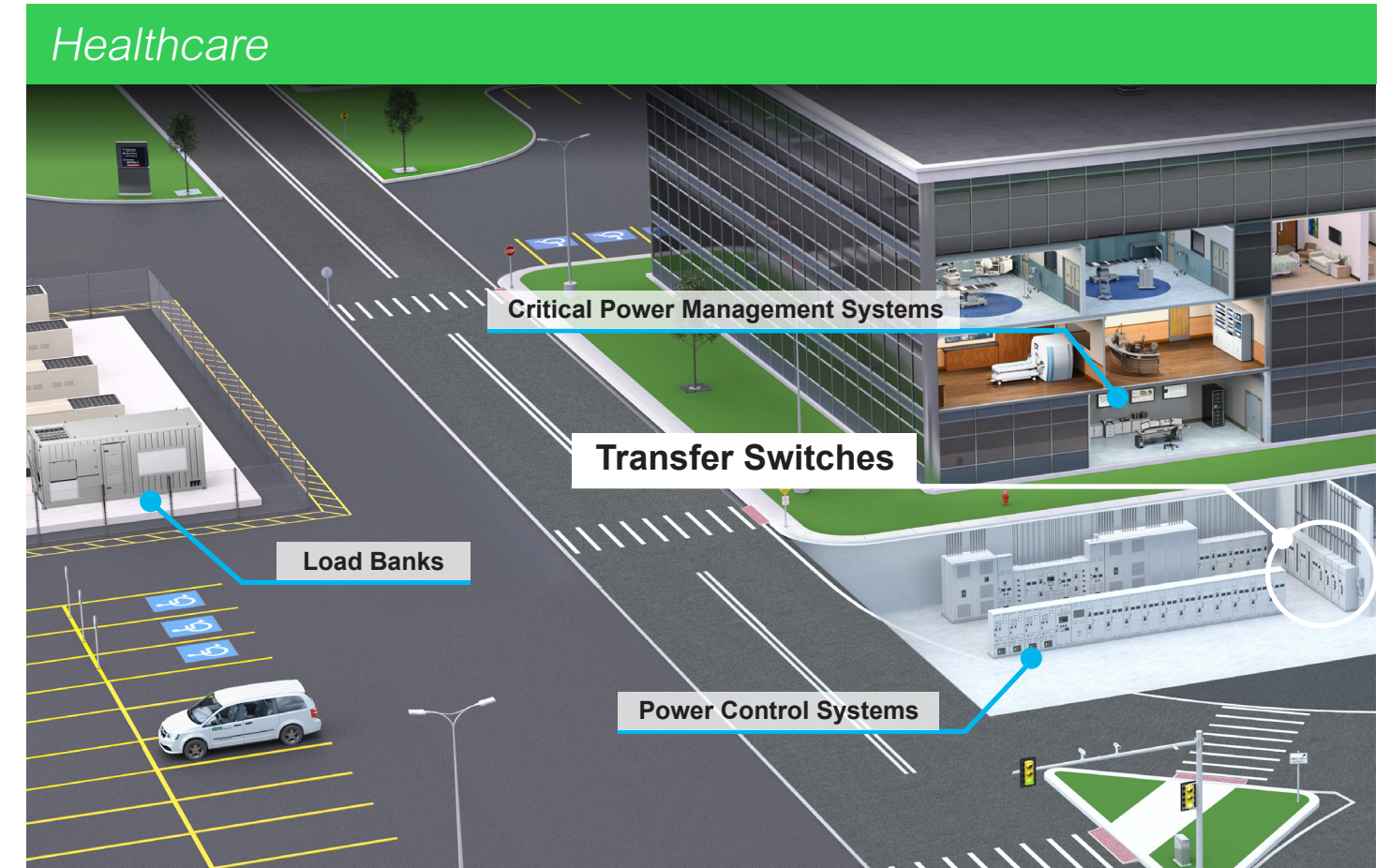

ASCO Transfer Switches make backup power possible. They enhance power availability by transferring electrical loads to alternate sources of power. From simple backup solutions to mission-critical facilities, transfer switches connect backup power to enhance safety and sustain operations.



ASCO Solutions

Critical Power Equipment for a Wide Range of Applications

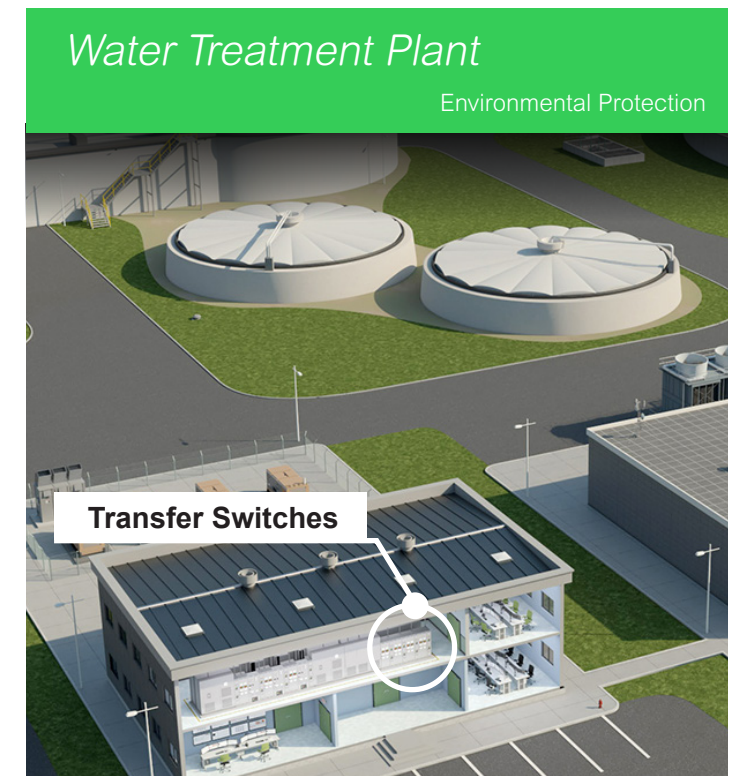
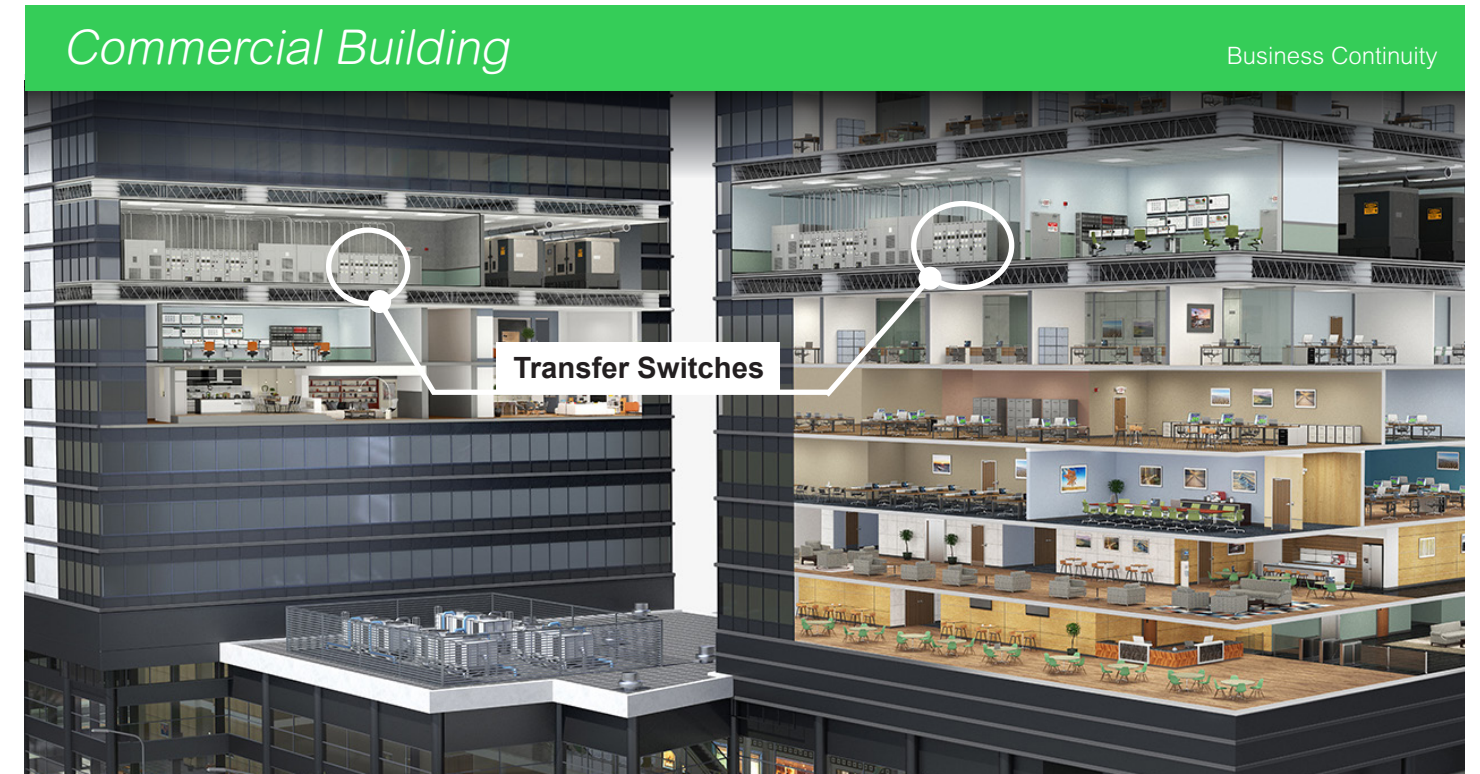
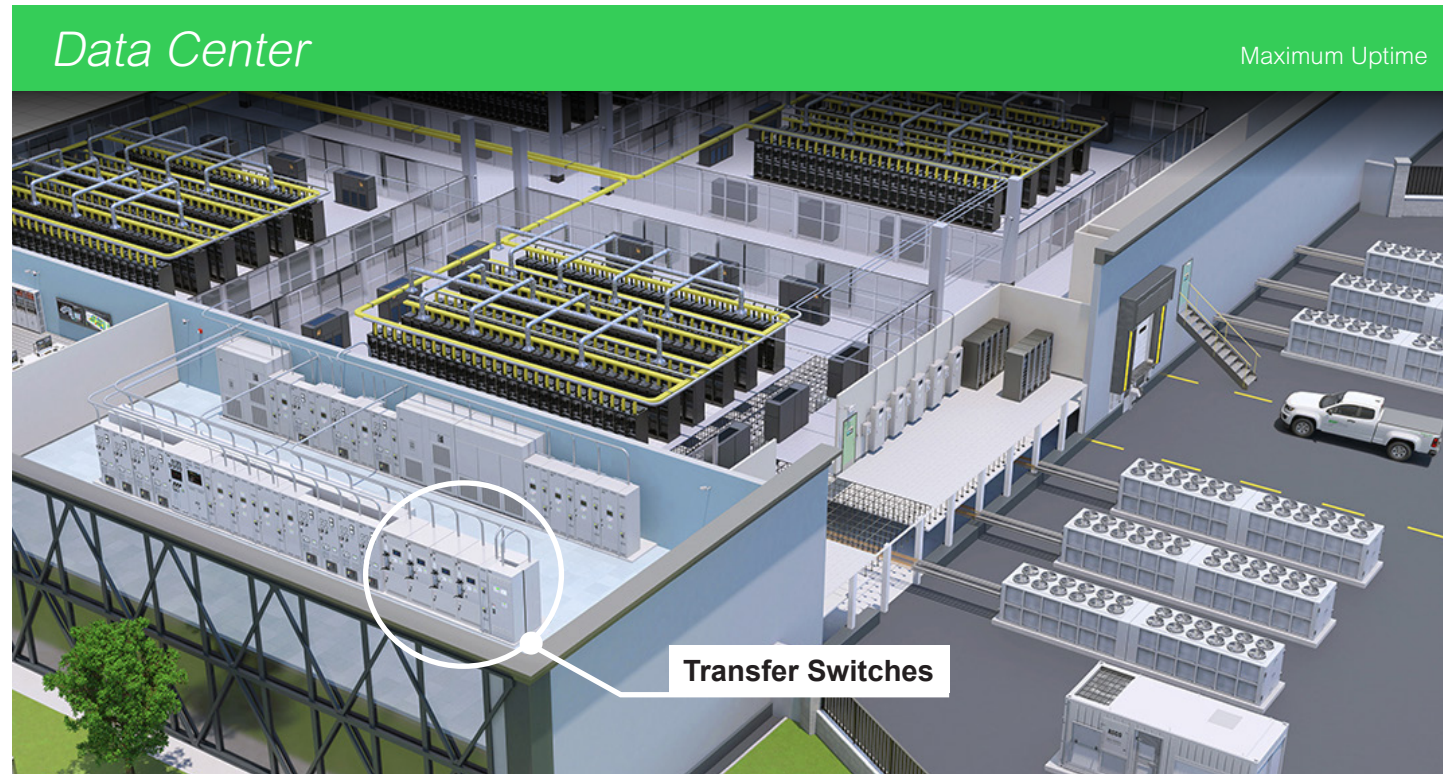

Transfer Switch Basics

Transfer switches are installed in power distribution systems between power sources and electrical loads. Transfer switches safely switch loads between two isolated sources of power.

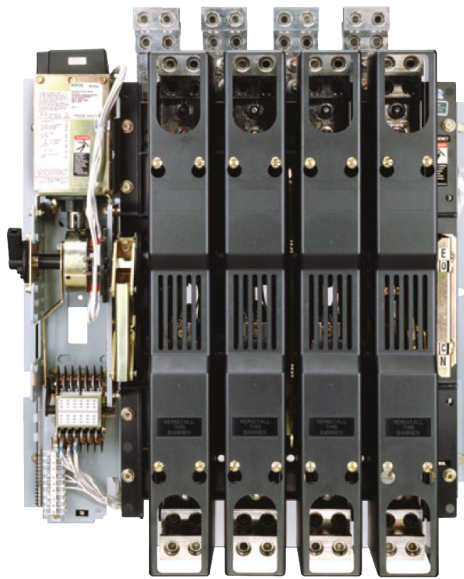

4-Pole Transfer Switching Mechanism

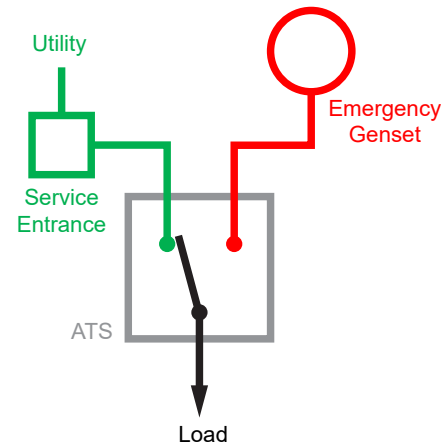

Automatic transfer switches provide the following essential functions without human intervention:

- Carry rated current continuously
- Detect power failure on primary source
- Start alternate power source
- Transfer load
- Sense restoration of power to primary power source
- Re-transfer load to primary source

Supporting Information: [Transfer Mechanism Basics](#)

Listings



Every ASCO Transfer Switch is listed to *UL 1008 – Standard for Safety – Transfer Switch Equipment*. UL 1008 testing requires enduring high overload and fault currents for up to thousands of switching cycles to ensure the highest levels of safety, reliability, and longevity.

Supporting Information: [UL 1008 Transfer Switch Withstand and Closing Ratings and Performance Testing for Transfer Switches](#)

Ratings

Every ASCO Transfer Switch offers Withstand and Closing Ratings indicating that amount of current it can withstand under short circuit conditions. ASCO Transfer Switches offer Time-Based Ratings to support selective coordination of fault-clearing devices used in power distribution systems to obtain these ratings.

Automatic Transfer Switch Components

Enclosure

Available in a range of UL-rated types, rugged enclosures protect equipment and ensure promote reliability for a variety of indoor and outdoor environments.



Transfer Mechanism

Electrically operated and mechanically held, solenoid-powered operating mechanisms reliably transfer load quickly for even the most demanding applications.

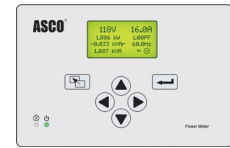
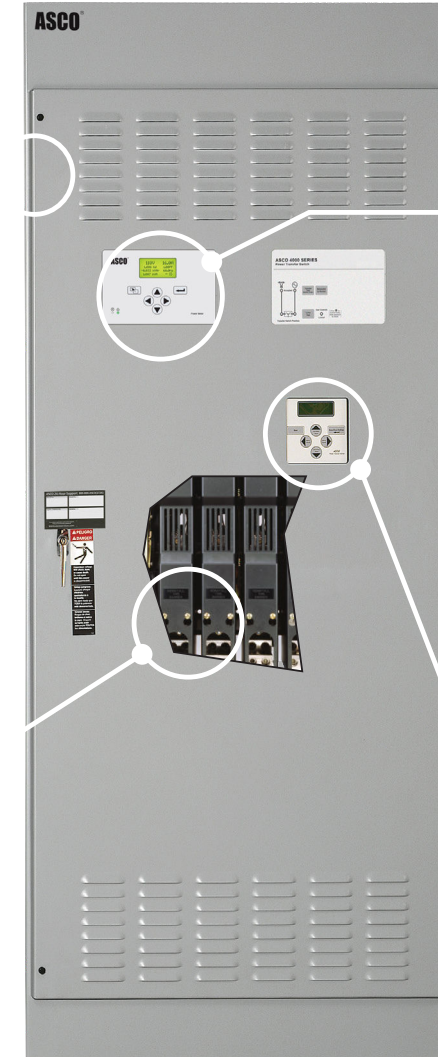

Communications and Metering

From simple indicators to remote annunciators, from real-time monitoring and control to interfacing building automation systems, communication features increase usability and power availability.



Controller

Electronic controller stores operating criteria, senses electrical conditions, executes transfer sequences, and stores operational data.

Transfer switch models differ by type of operation:



Automatic

Automatic models switch loads to emergency power and back again whenever outages occur, without human intervention.



Non-Automatic

Non-Automatic models use operator initiated, local or remote electrical controls to transfer loads on command.



Manual

The simplest type, manual transfer switches require a person to operate a mechanical switching mechanism.

Design and Integrations

Integrating functions extends transfer switch value

Standard Transfer Switch



Reliably transfer electrical load between sources of power.

Bypass-Isolation Transfer Switch



Bypass feature enables concurrent maintainability - Isolation of transfer mechanism facilitates service and repair.

Service Entrance Transfer Switch



Simplify design, procurement, and installation by incorporating service disconnect in a transfer switch enclosure or lineup.

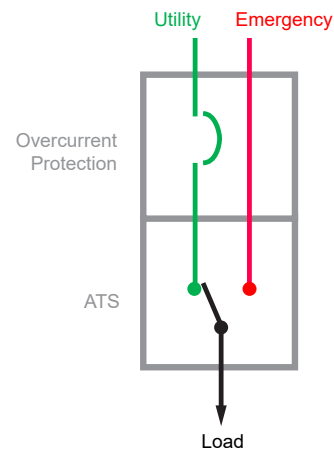
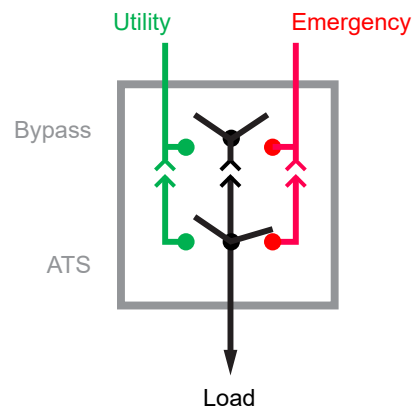
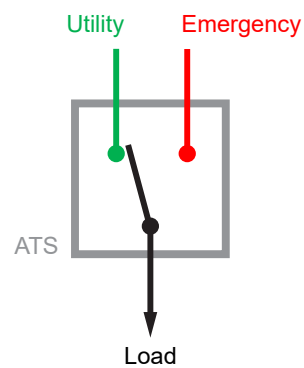

Neutral Configurations

Transfer switches differ by neutral configurations

Solid Neutral

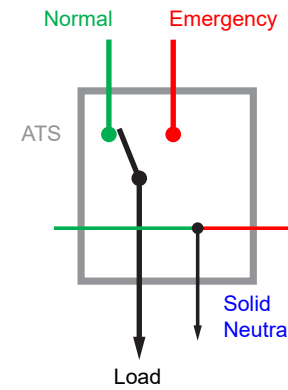

Standard configuration for power distribution systems with a single grounding electrode.

Switched Neutral

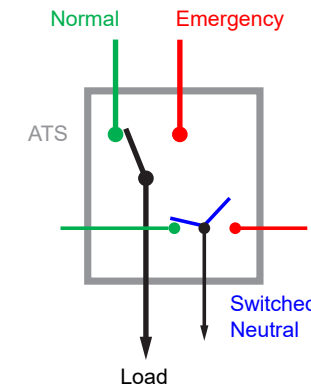

Switched neutral for transferring load between separately grounded systems.

Overlapping Neutral

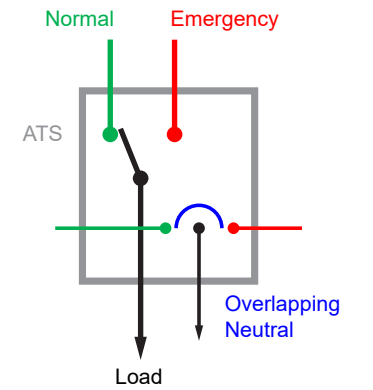

Overlapping neutral for transferring load between separately derived systems without interrupting neutral connectivity.

Supporting Information: [Switching the Neutral Conductor](#)

“With nine hospitals on the line, ASCO helps me sleep well at night.” Tom M., Facility Engineering Director



Transition Modes

Switch mechanisms differ by transfer sequence

Open Transition

- “Break-Before-Make” Operation
- Popular for Resistive & Mixed Loads
- Used Across a Wide Range of Facilities & Industries
- Standard In-Phase Transfer Capability

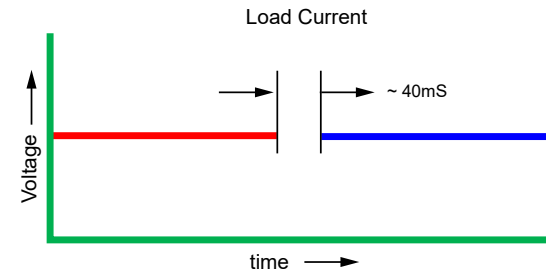

Delayed Transition

- “Break-Wait-Make” Operation
- Inductive & Motor Load Applications
- Allows Residual Voltages of Motors & Inductive Devices to Decay Prior to Avoid Damaging Transient Currents

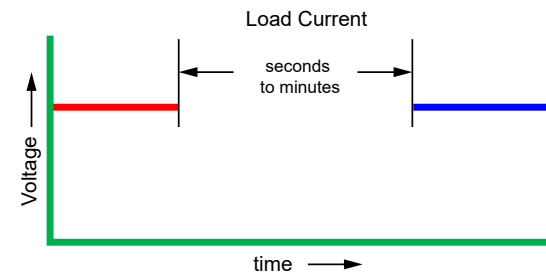

Closed Transition

- “Make-Before-Break” Transfers without Momentary Power Interruption
- Reduces Electrical Disturbance to Downstream Loads when Transferring Between Two Live Sources
- For Mission-Critical Operations, Healthcare Facilities, & Data Centers

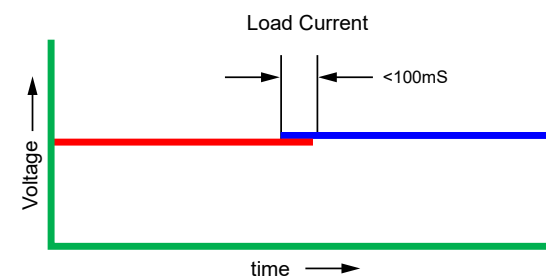

Soft Load Transition

- Ramps Down One Source While Increasing Power from a Source
- Avoids Excessive Block Loading of Generators
- Useful Where Load Exceeds 80% of Generator Capacity

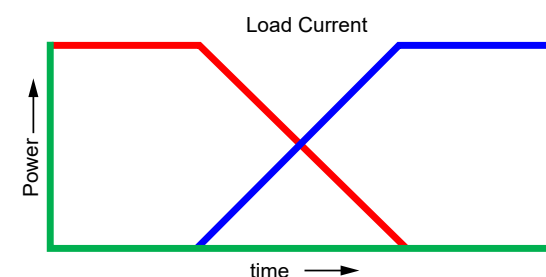

Custom Engineered Transfer Switch and Distribution

“Value-Added Transfer Switches”

Custom switches increase value by integrating service, distribution, and control features in custom-engineered designs.

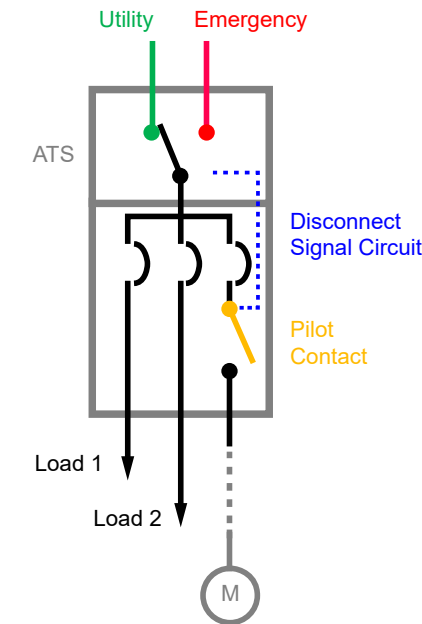

Customization options include:

- Integrated Distribution Breakers
- Source Fusing
- Bus Riser

Custom-Engineered Transfer Switches can offer:

- Reduced Space Requirements
- Reduced Lead and Construction Times
- Reduced Installation Labor
- Enhanced Quality Control



Transfer Switch Product Lines

7000 SERIES

Custom engineered for healthcare, data center, and mission critical facilities. They are the industry leading technology for the widest range of applications.

- Hospitals
- Data Centers
- Mission Critical Facilities



4000 SERIES

Sophisticated control for large commercial and industrial loads. 4000 SERIES switches have premium features in a configured-to-order solution.

- Large Commercial Applications
- Large Industrial Facilities
- Water Treatment Plants



SERIES 300

Standard designs for commercial and light industrial facilities that are simple to procure, install and commission.

- Outpatient Healthcare Facilities
- Small & Midsize Businesses
- Light Industrial Applications
- Integrated & Stand-Alone Quick Connects



SERIES 185

Economical designs for homes and small businesses.

- Small Businesses
- Residential Applications



Transfer Switch Product Lines

Product Range	Product SERIES			
	7000	4000	300	185
Voltages	115-600 V, 5-15 kV	115-600 V	115-600 V	220-240 V
Ampacities	30-4000 A	30-4000 A	30-3000 A	100-400 A
Poles	2, 3, or 4	2, 3, or 4	2, 3, or 4	2
Withstand & Closing Ratings	10-200 kA	10-200 kA	22-200 kA	10-200 kA
Time-Based Ratings	36-65 kA	36-65 kA	36-65 kA	-
Designs				
Standard Transfer Switch	X	X	X	X
Bypass-Isolation Transfer Switch	X	-	-	-
Service Entrance Transfer Switch	X	X	X	X
Custom Engineered Transfer Switch	X	-	-	-
Range of Accessories	XXXXX	XXX	XXX	X
Transition Modes				
Open Transition	X	X	X	X
Delayed Transition	X	X	X	-
Closed Transition	X	X	-	-
Soft-Load Transition	X	-	-	-
Neutral Configurations				
Solid Neutral	X	X	X	X
Switched Neutral	X	X	X	-
Overlapping Neutral	X	-	-	-
Quick Connects				
Integrated Panel	-	-	X	-
Stand-Alone Panel	-	-	X	-

Resource Finder

Resource Finder	Product SERIES			
	7000	4000	300	185
Product Web Page	Low Voltage Web Page Medium Voltage Web Page	Web Page	Web Page	Web Page
Product Brochure	Low Voltage Pub.3040 Medium Voltage Pub.2060	Pub.3144	Pub.1195	Pub.3214
Available Ratings	View Supporting Documentation			
White Papers	View Transfer Switch Papers			
Technical Articles	View Transfer Switch Articles			
Videos	View Transfer Switch Videos			

Life Is On

Schneider
Electric™

ASCO Power Technologies - Global Headquarters
160 Park Avenue
Florham Park, NJ 07932
Tel: 800 800 ASCO

www.ascopower.com
customer care@ascopower.com